

Manugraph DGM Closed Loop Infeed

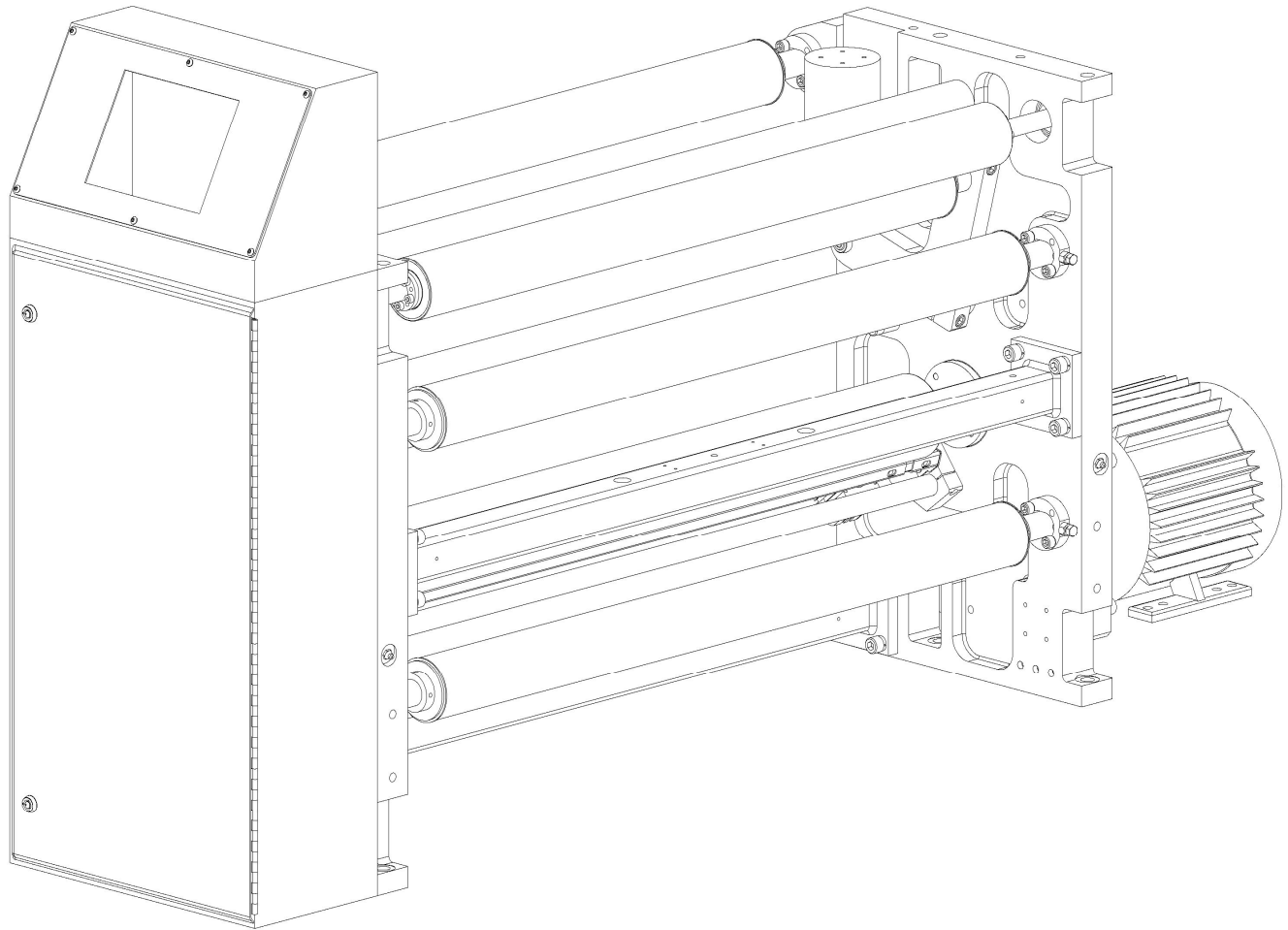

Features:

- Maximum web width of 36"
- Maximum speed of 50,000 imp/hr
- Self contained dancer controlled closed loop design.
- Requires no encoders to be mounted to the press line.
- 6" touch screen mounted to infeed for local control.
- *Optional* - 10" remote touch screen control for tension control at the console.
- Motor driven 4" infeed roller with pneumatically actuated rubber coated nip roller.
- Can be configured as single or stacked for two web capability.
- Compact footprint - 16" wide x 30" tall (single infeed), accommodates most existing press spacing.
- Sturdy construction uses 2" thick cast iron frames & 3 cross members per each infeed.
- Web feed function in manual mode.

For additional information & pricing call MDGM sales @ 1-800-346-6119



Closed Loop Infeed Cross Section View

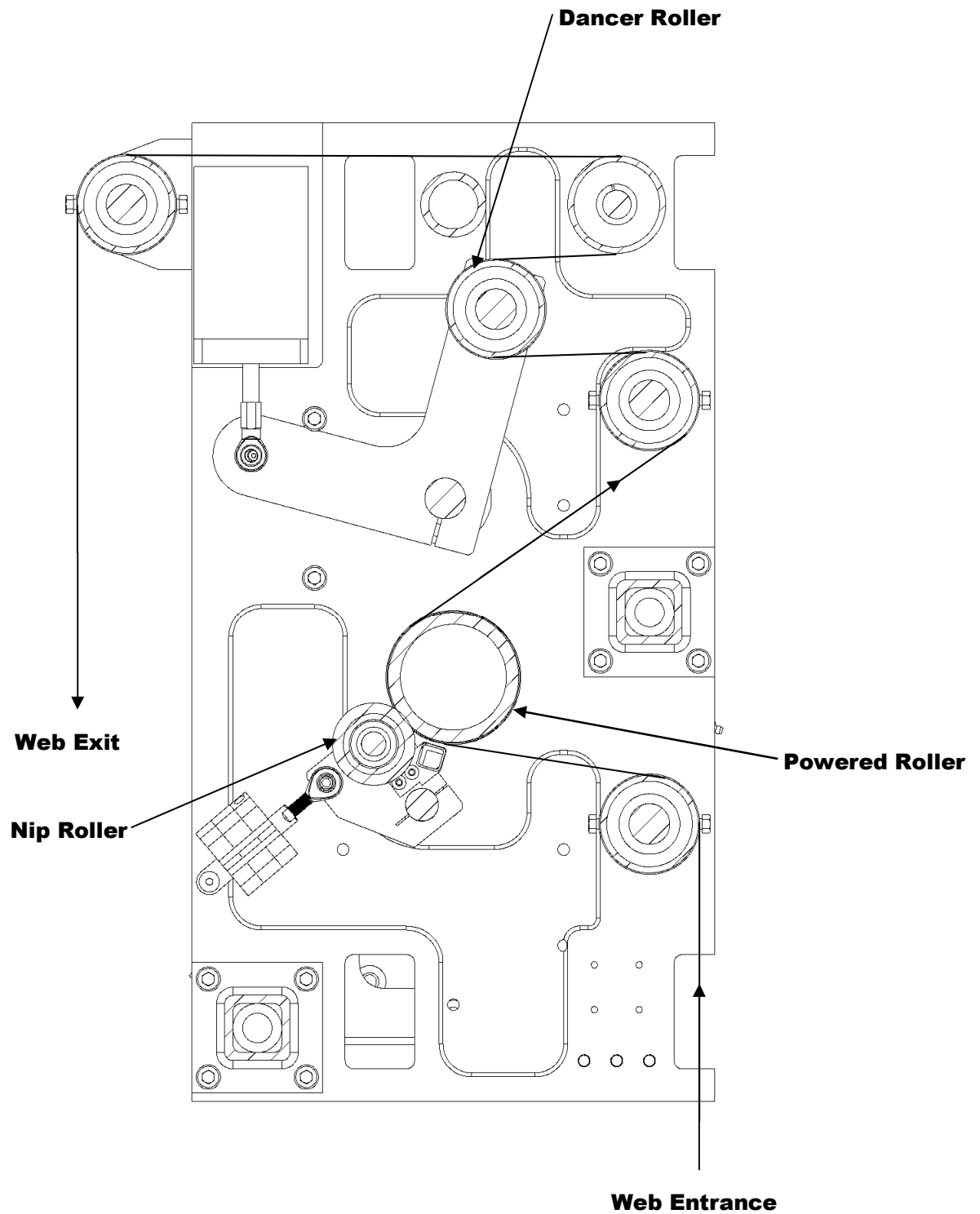

Infeed mounted touch screen

Auto Mode Screen

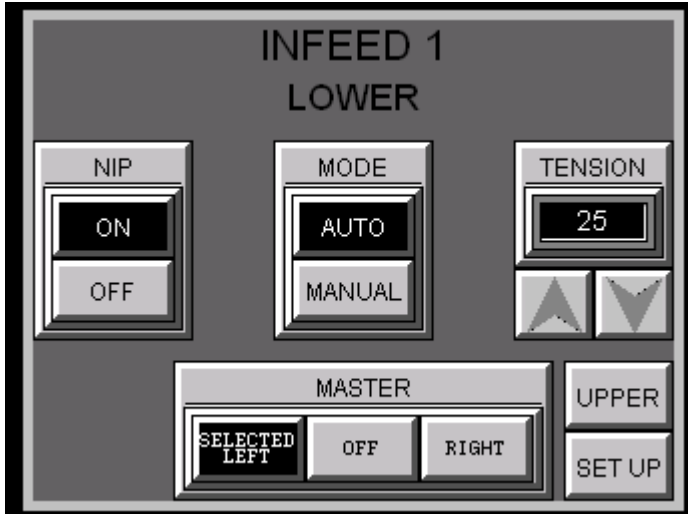

Manual Mode Screen

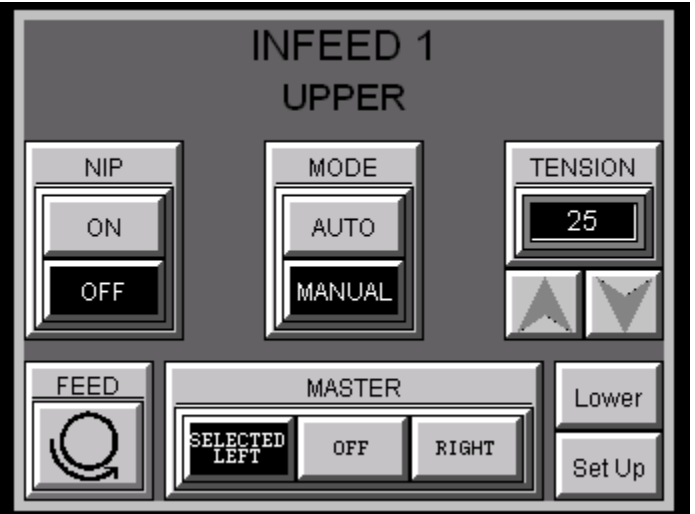

Remote mounted touch screen

